

APPLICATION NOTES



Application Note 3005:

DIDO Control Wiring

The DIDO (Digital Input Digital Output) Controller can enable/disable, start/stop, turn on/turn off and schedule general equipment associated with the DIDO Controller. The controller has 2 channels which consist of 1 DI (digital input) and 1 DO (digital output) per channel. The DIDO Controller should be mounted in an enclosure. A 24 VDC power supply and interposing relay are required. The Digital Outputs can only switch DC voltage. **DO NOT APPLY AC VOLTAGE** to controller.

The controller is an M-NET device which requires addressing. The addressing range is from 1 – 50. The DIDO controller is wired to the M-NET using either the TB-7 or TB3 transmission line of the outdoor unit. The M-NET transmission line must connect to the CN17 terminal block of the DIDO controller. Only the M-NET circuitry of this device is powered by the M-NET transmission line. A separate 24 VDC power supply will be needed to power the DIDO controller.

The DIDO Controller requires the following component wiring:

- DC Power Supply – 24 VDC
- Relay
- M-NET
- Terminal block wiring per channel used (input/output)

Input Wiring

There are 2 digital inputs (DI) associated with each DIDO controller. As illustrated in Figure 1, each input channel has 2 contact points that can monitor ON/OFF and Normal/Error status for each connected piece of general equipment. Connect the start/stop (ON/OFF) inputs so that closing the contact operates (ON) the device and opening the contact stops (OFF) the device.

Channel 1

CN10: ON/OFF Status

CN11: Error/Normal Status

Channel 2

CN19: ON/OFF Status

CN20: Error/Normal Status

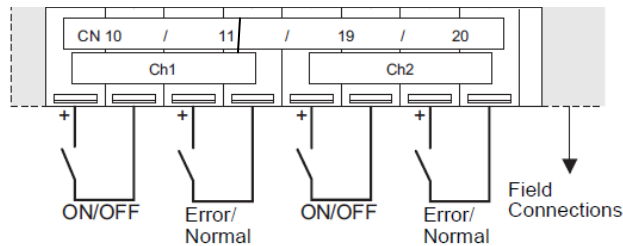

Figure 1. Digital Input Wiring

Output Wiring

There are 2 digital outputs (DO) associated with each DIDO controller shown in Figure 2. Each channel must be powered by 24 VDC. When 24 VDC is applied to the DO of channel 1 and/or 2, the normally open circuit closes providing 24 VDC to the relay from the DIDO controller. DIDO Wiring to the power supply and relay is shown in Figure 3.

Notes:

1. Do not use DIDO controller for fire alarm or life safety control.
2. For detailed installation instructions see the DIDO Installation/Instruction Manual

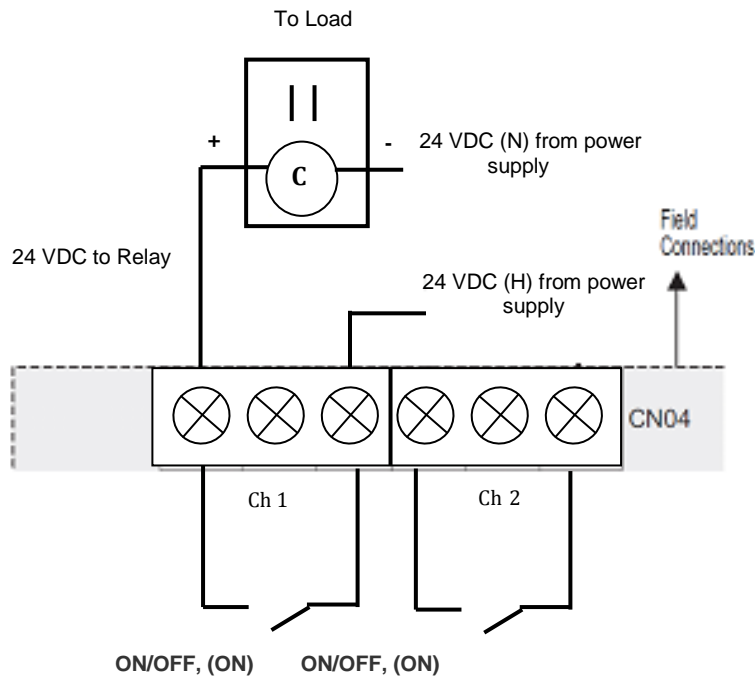

Operate (ON) output: Contacts closed
 Stop (OFF) output: Contacts open

Figure 2. Digital Output Wiring

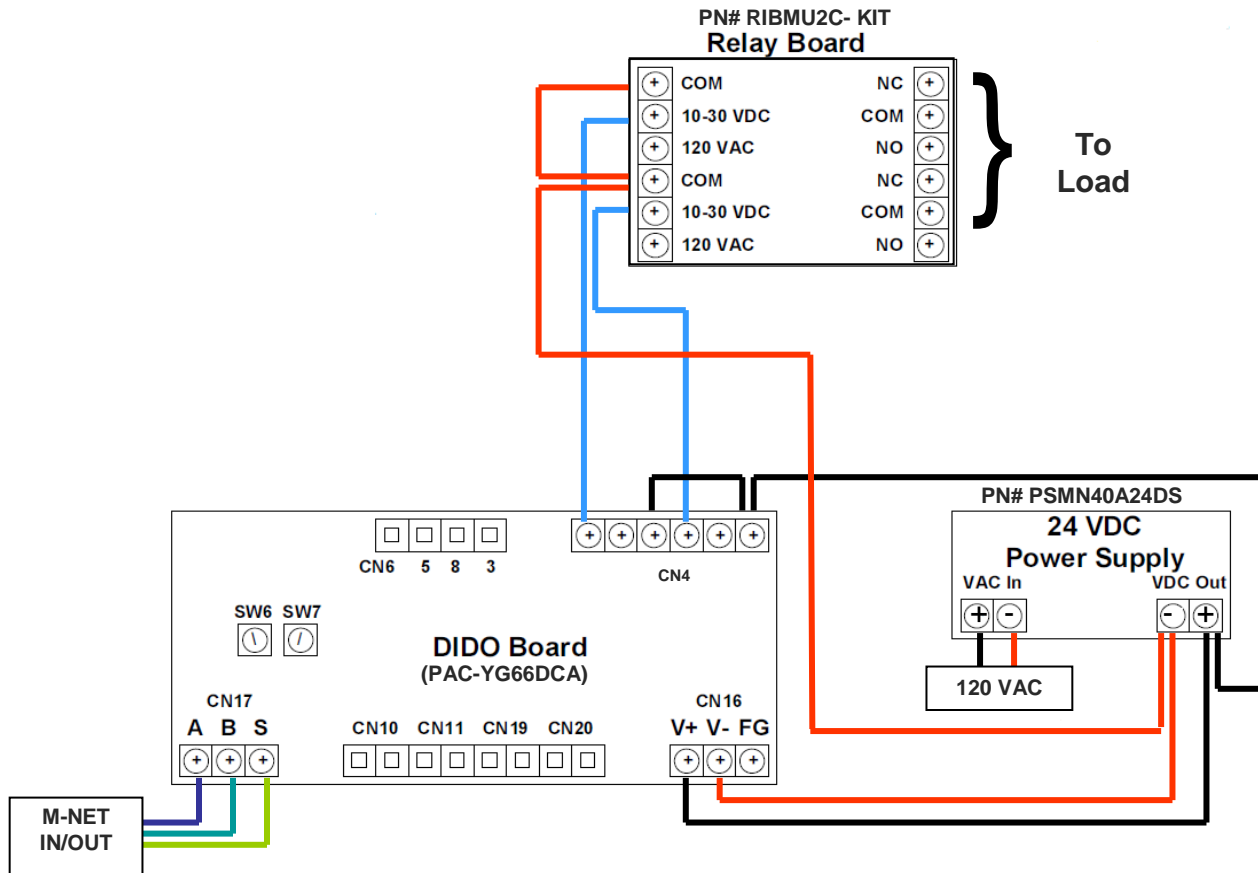

Figure 3. DIDO Wiring to Power Supply and Relay